

1. Complete drawing of 900W/1 HP, 6Mtr Staging, 5KL Solar Dual Pump structure & Civil Works

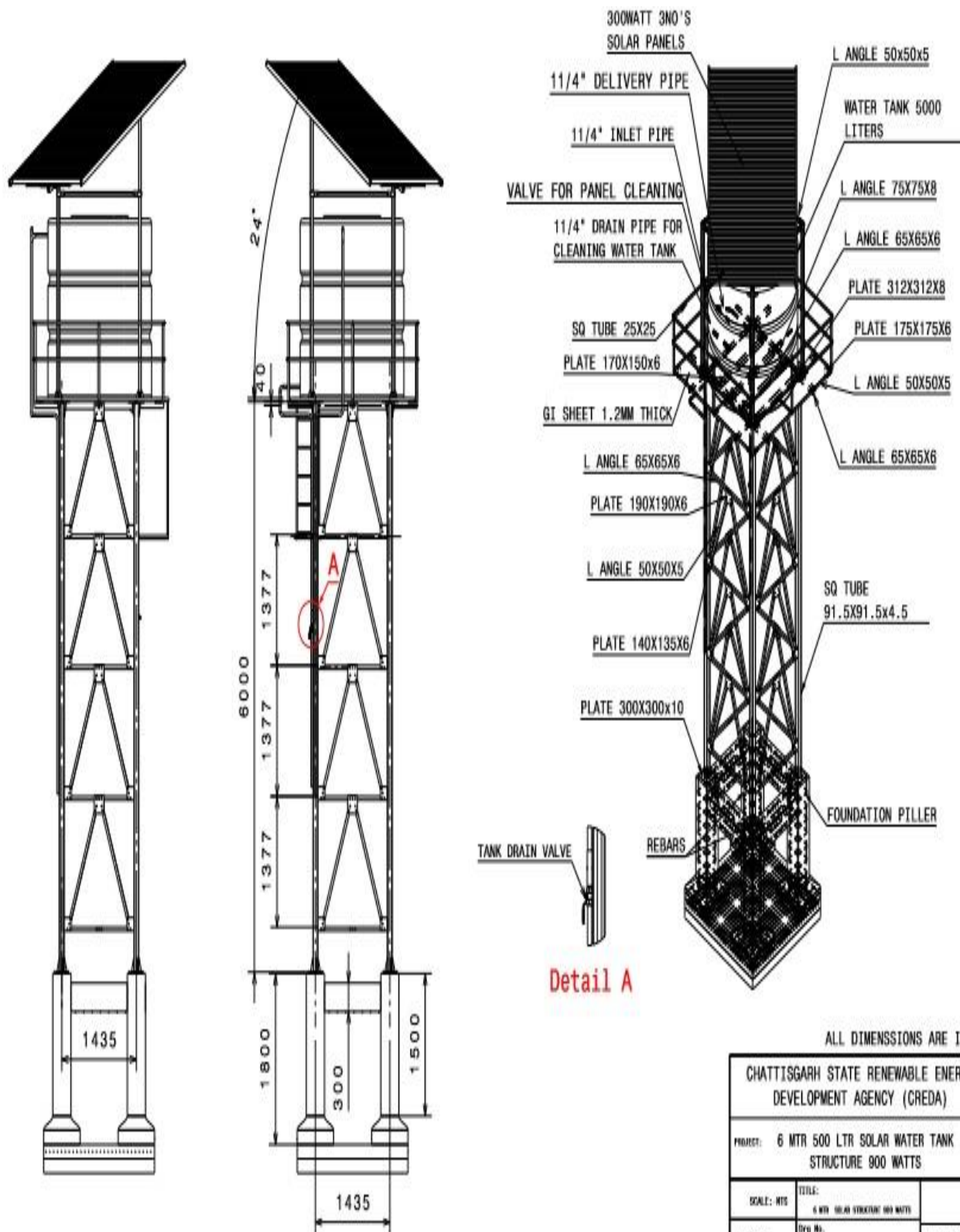

| | | |
|---|---|------------------------------|
| CHATTISGARH STATE RENEWABLE ENERGY DEVELOPMENT AGENCY (CREDA) | | |
| PROJECT: 6 MTR 500 LTR SOLAR WATER TANK STRUCTURE 900 WATTS | | |
| SCALE: NTS | TITLE: 6 MTR SOLAR STRUCTURE 900 WATTS | |
| projection | DRY No. CREDA-001 | SHEET No. 1 OF 2 REV - 00 |

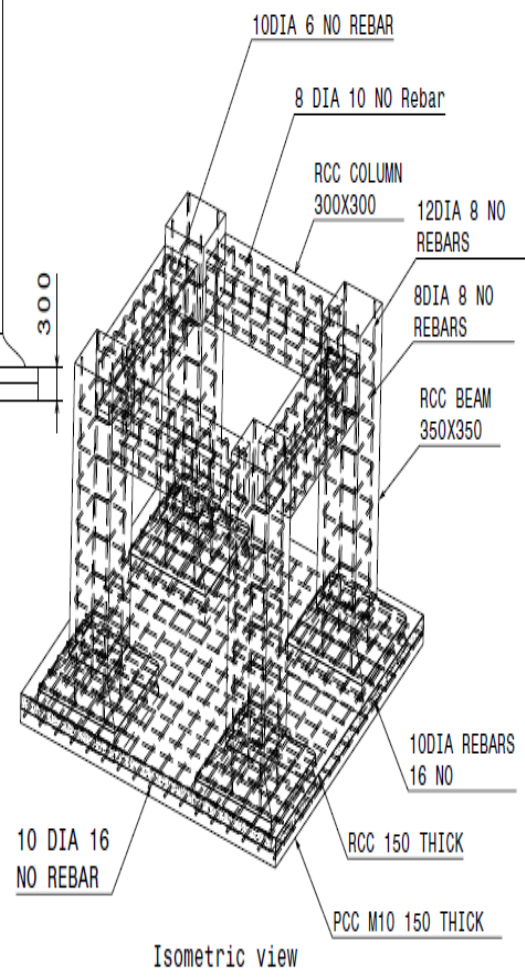
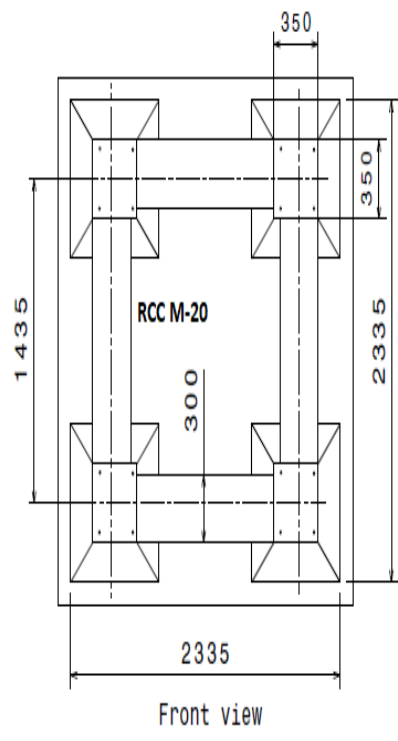
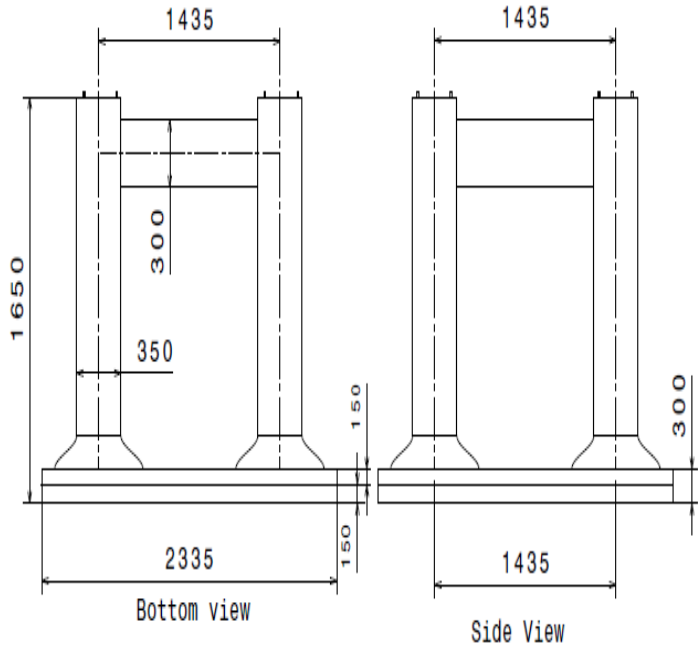

ALL DIMENSIONS IN MM

| | | | |
|---|--------------------|--|--------------------|
| This drawing is our property. it can't be reproduced or communicated without our written agreement. | | CHATTISGARH STATE RENEWABLE ENERGY DEVELOPMENT AGENCY (CREDA) | |
| CLIENT : | | PROJECT: FOUNDATION DRAWING FOR GALVANISED STEEL STRUCTURE STAGING -6MTR | |
| Drawn By | GONTHAM 20.02.2018 | SCALE:-NTS | TITLE : |
| Checked By | | | Org No. |
| Designed By | | | MCP-CR-FGSSS-6 MTR |

Structure Part Drawings (900WATT, 6Mtr, 01 HP,5KL)

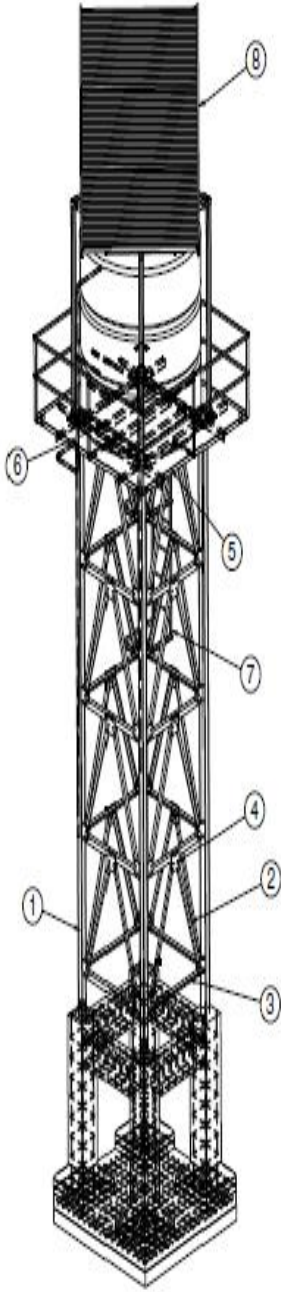

ISOMETRIC VIEW

| | | |
|---|---|----------------------------------|
| CHATTISGARH STATE RENEWABLE ENERGY DEVELOPMENT AGENCY (CREDA) | | |
| PROJECT TITLE 6 MTR 5000 LTR SOLAR WATER TANK STRUCTURE 900 WATTS | | |
| SCALE: -NTS | TITLE 6 MTR 5000 LTR SOLAR WATER TANK STRUCTURE 900 WATTS | REF No. AK |
| projection | Drg No. CREDA 002 | SHEET No. 1 OF 9 REV - 01 |

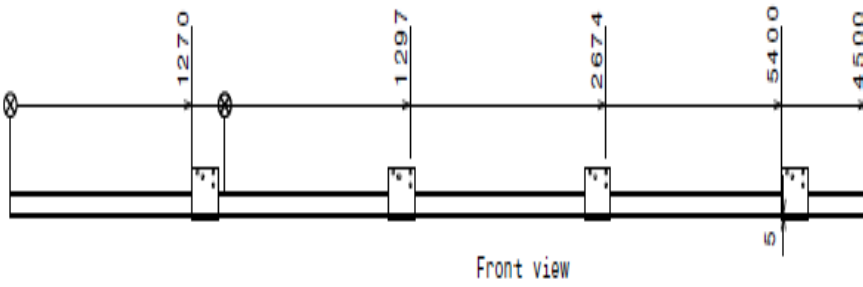

Front view

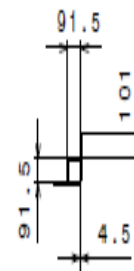

Left view

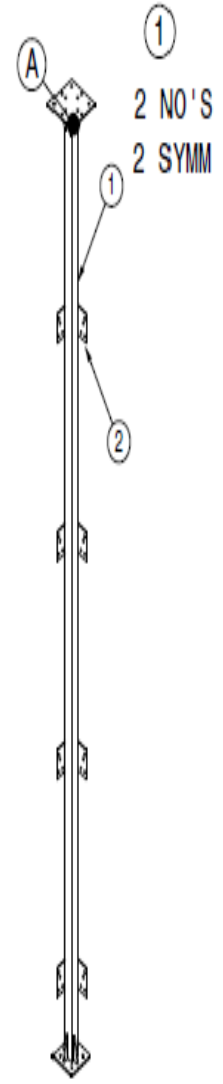

Isometric view

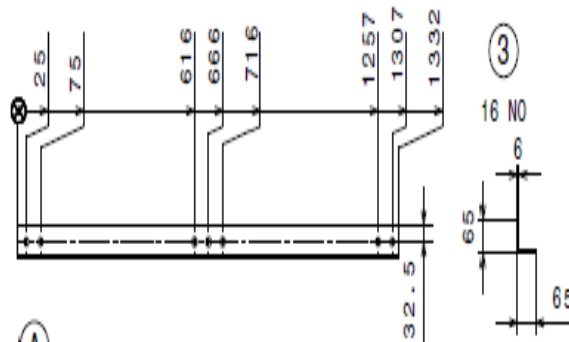

(A)
4 NOS

Front View

Left View

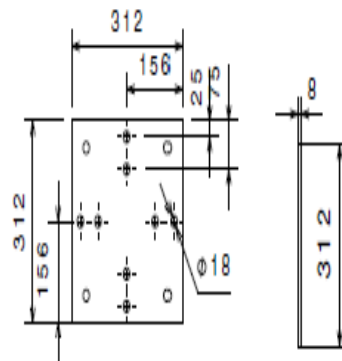

(A)
4 NOS

Front View

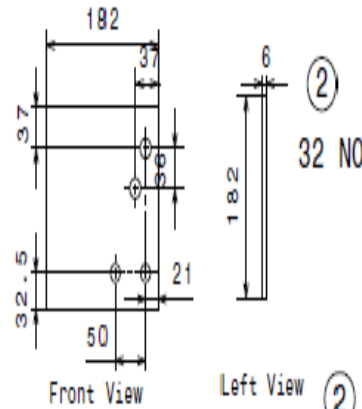

Front View

Left View

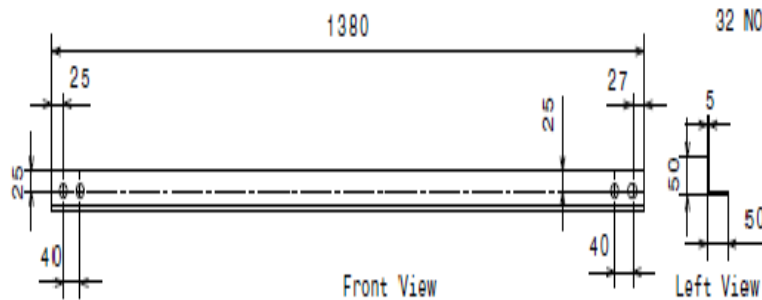

Front View

Left View

| | | |
|---|--|------------------------------|
| CHATTISGARH STATE RENEWABLE ENERGY DEVELOPMENT AGENCY (CREDA) | | |
| PROJECT TITLE 6 MTR 5000 LTR SOLAR WATER TANK STRUCTURE 900 WATTS | | |
| SCALE: -NTS | TITLE 6 MTR 5000 LTR SOLAR WATER TANK STRUCTURE 900 WATTS | REF No. AK |
| projection | Org. No. CREDA 002 | SHEET No. 2 OF 9 REV - 01 |

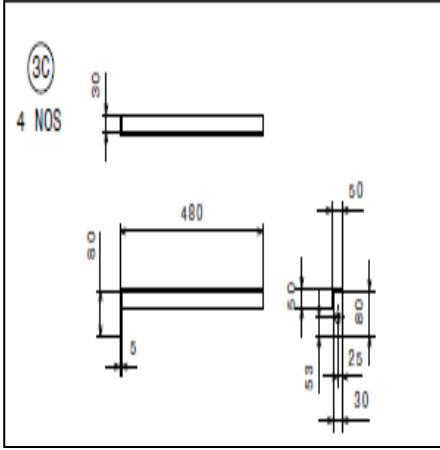
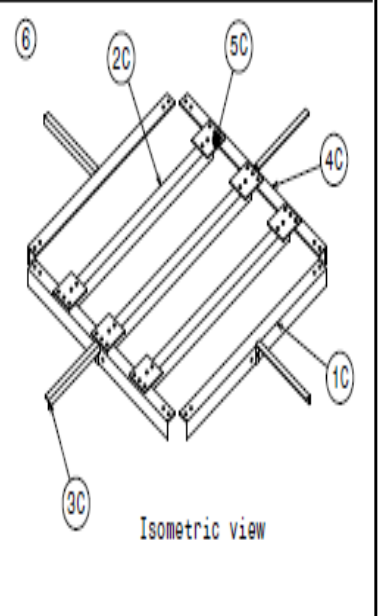
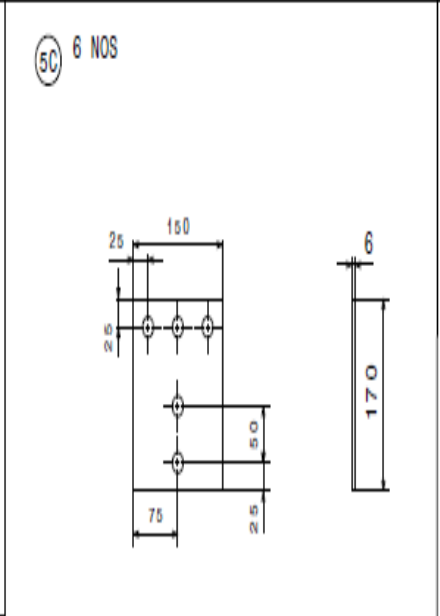
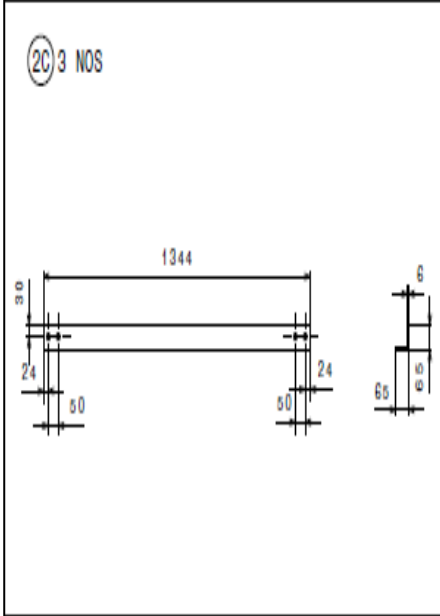
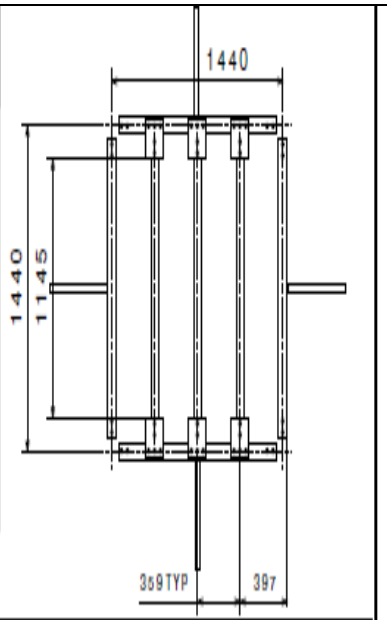
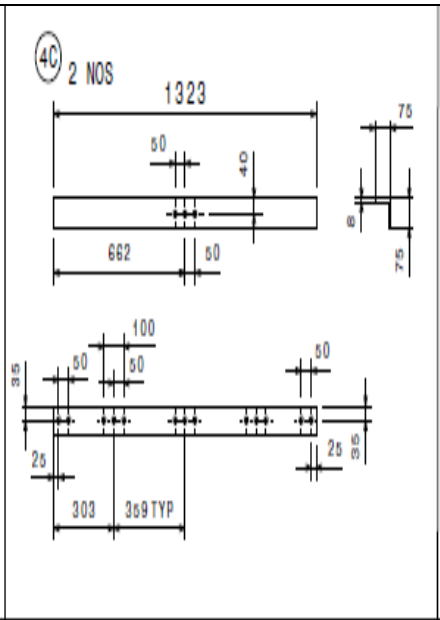
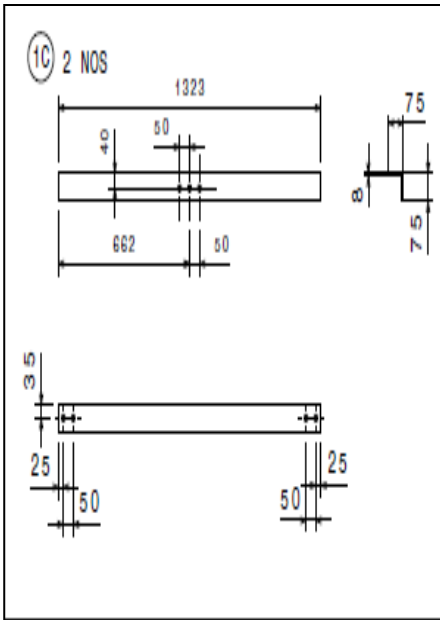

NOTE: ALL HOLES OF 18 DIA

ALL DIMENSIONS ARE IN MM

| | | |
|---|---|------------------|
| CHATTISGARH STATE RENEWABLE ENERGY DEVELOPMENT AGENCY (CREDA) | | |
| PROJECT TITLE 6 MTR 5000 LTR SOLAR WATER TANK STRUCTURE 000 MATTS | | |
| SCALE:- NTS | TITLE 6 MTR 5000 LTR SOLAR WATER TANK STRUCTURE 000 MATTS | REF No. AK |
| projection | Drwg No. CREDA 002 | SHEET No. 3 OF 3 |
| | | REV - 01 |

5

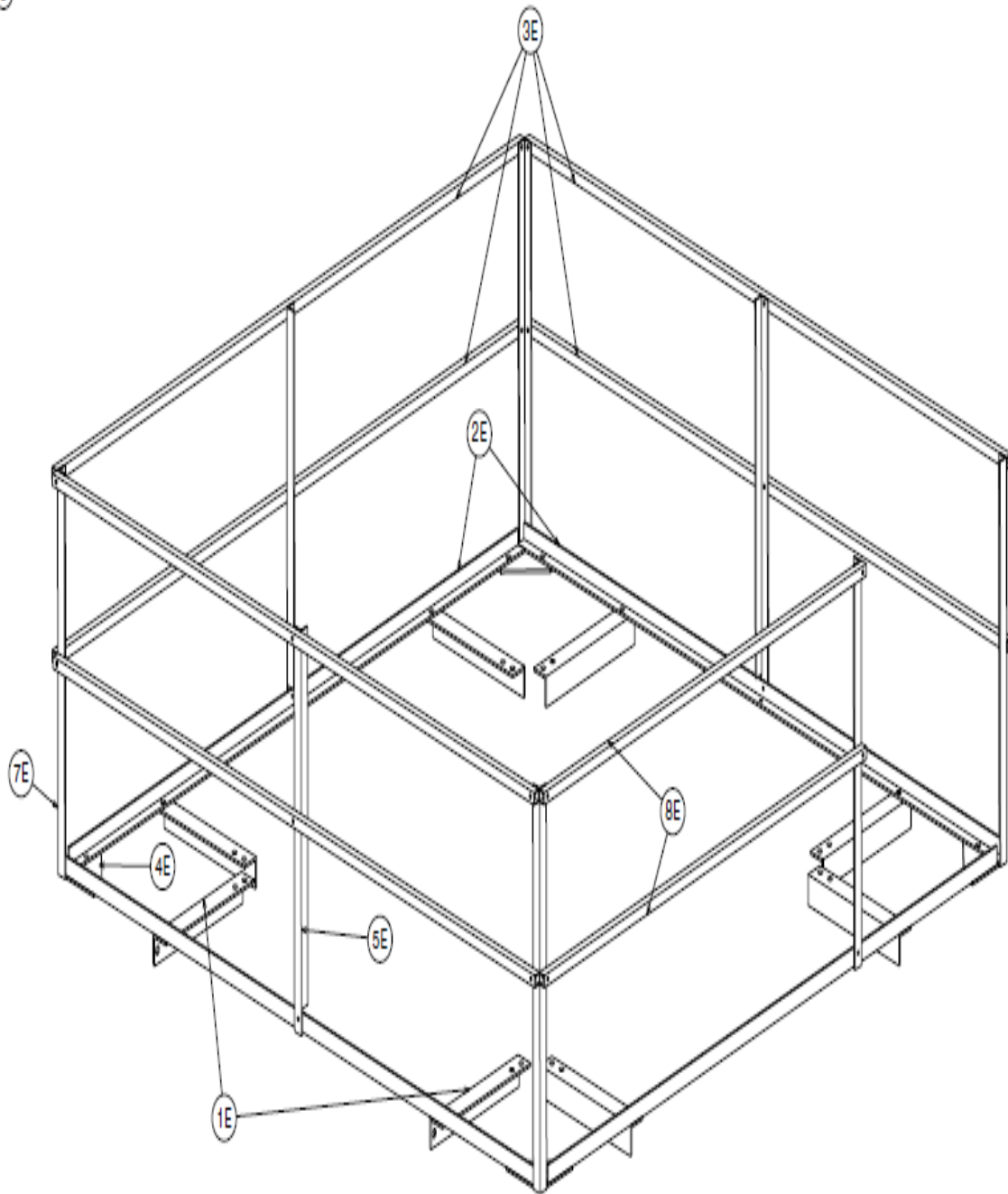

Isometric view

| | | |
|---|--|------------------------------|
| CHATTISGARH STATE RENEWABLE ENERGY DEVELOPMENT AGENCY (CREDA) | | |
| PROJECT TITLE 6 MTR 5000 LTR SOLAR WATER TANK STRUCTURE 900 WATTS | | |
| SCALE:- NTS | TITLE 6 MTR 5000 LTR SOLAR WATER TANK STRUCTURE 900 WATTS | SET No. AK |
| projection | Drwg No. CREDA 002 | SHEET No. 4 OF 8 REV - 01 |

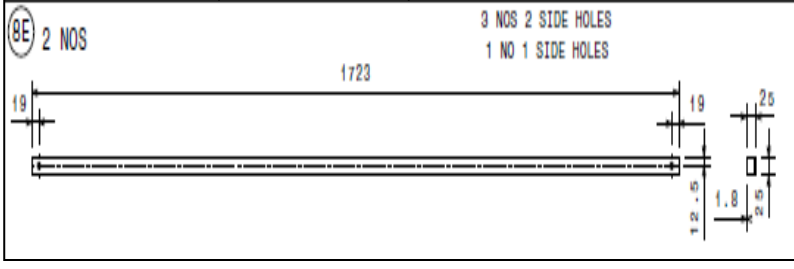
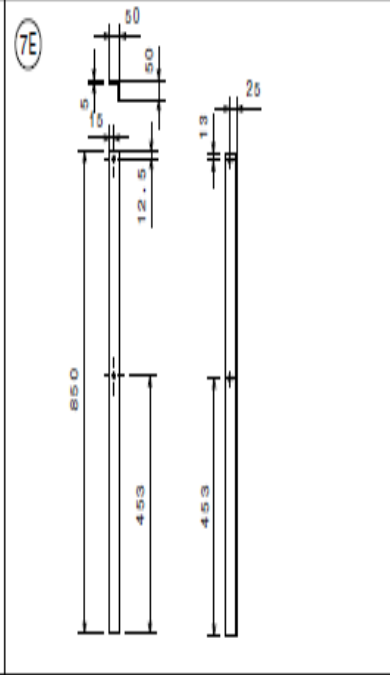
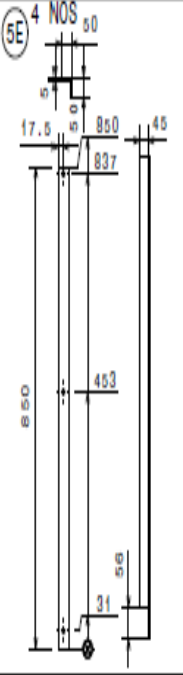
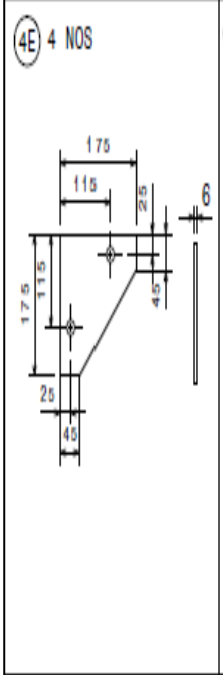
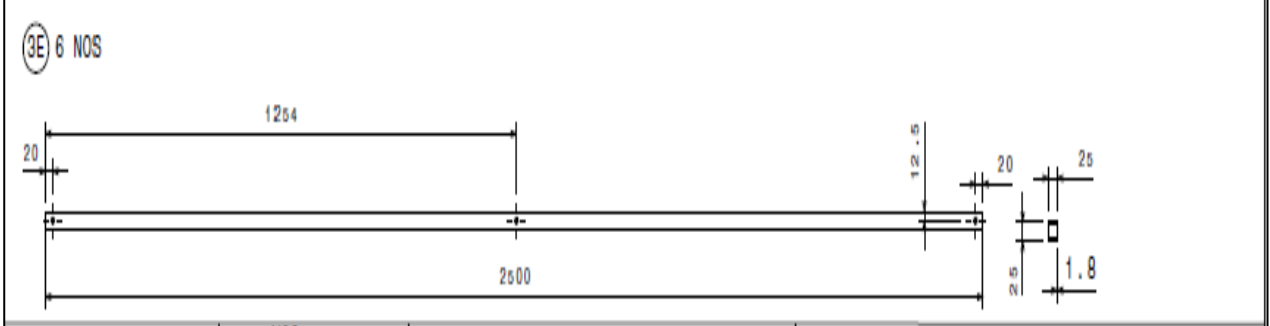
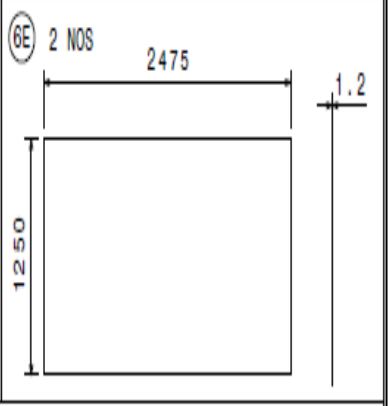
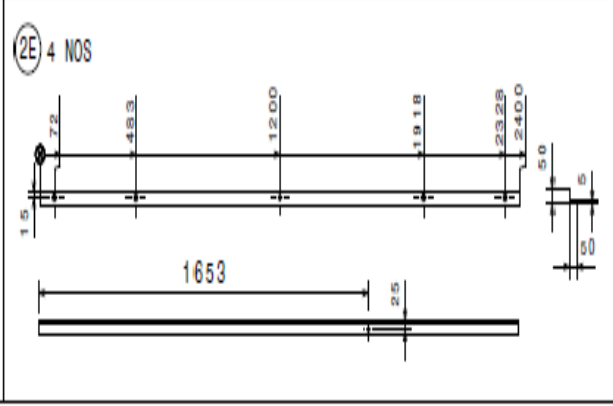
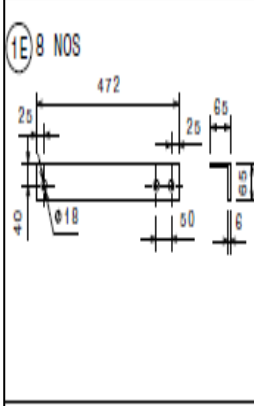

| | | |
|---|--|------------------|
| CHATTISGARH STATE RENEWABLE ENERGY DEVELOPMENT AGENCY (CREDA) | | |
| PROJECT TITLE 6 MTR 5000 LTR SOLAR WATER TANK STRUCTURE 900 WATTS | | |
| SCALE:- NTS | TITLE 6 MTR 5000 LTR SOLAR WATER TANK STRUCTURE 900 WATTS | REF No. AK |
| projection | Org No. CREDA 002 | SHEET No. 5 OF 9 |
| | | REV - 01 |

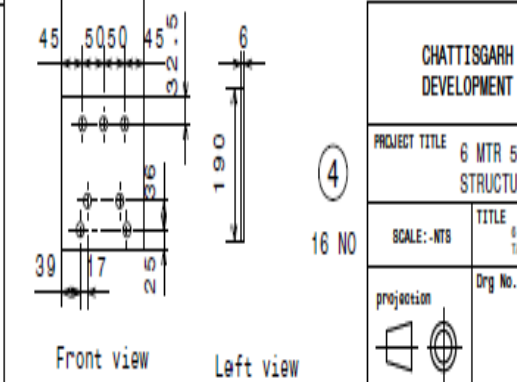
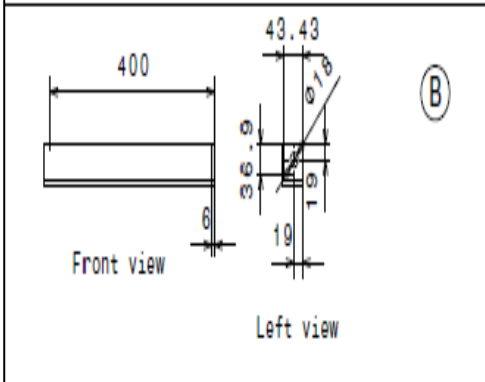
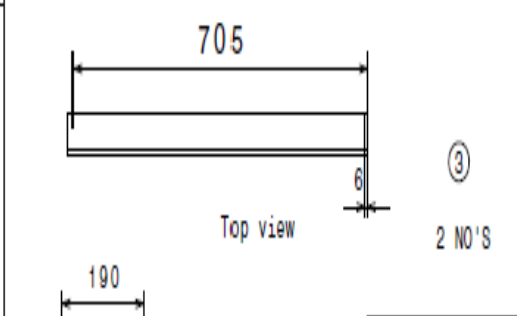
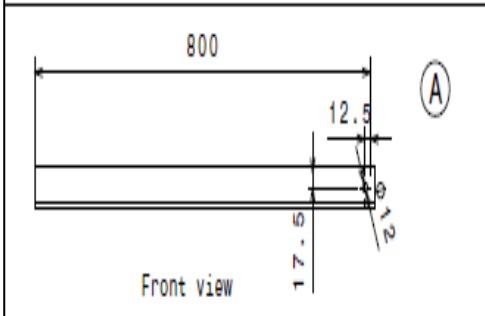
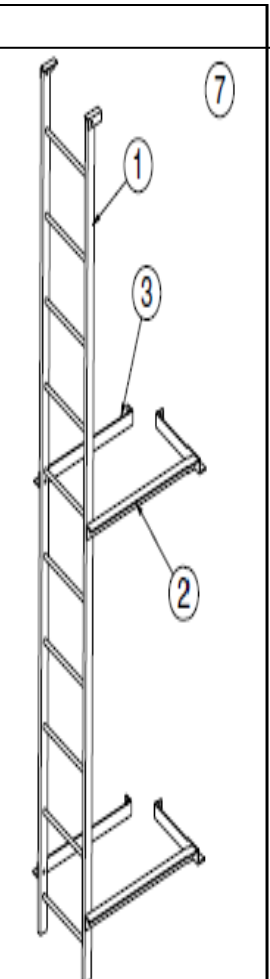
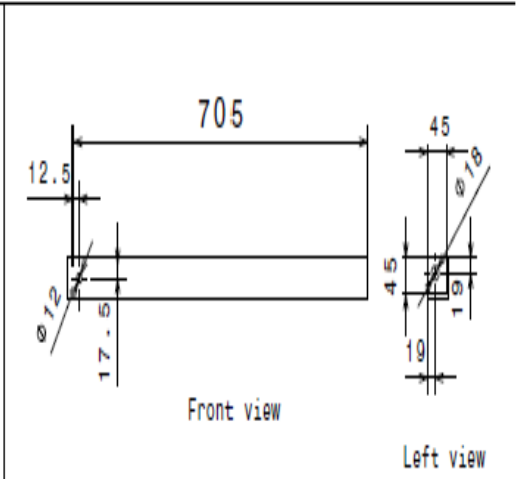
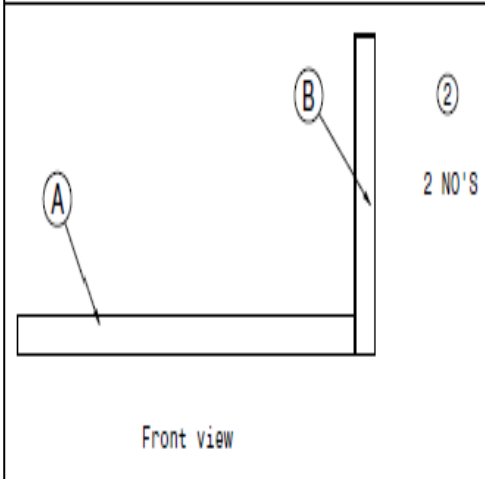
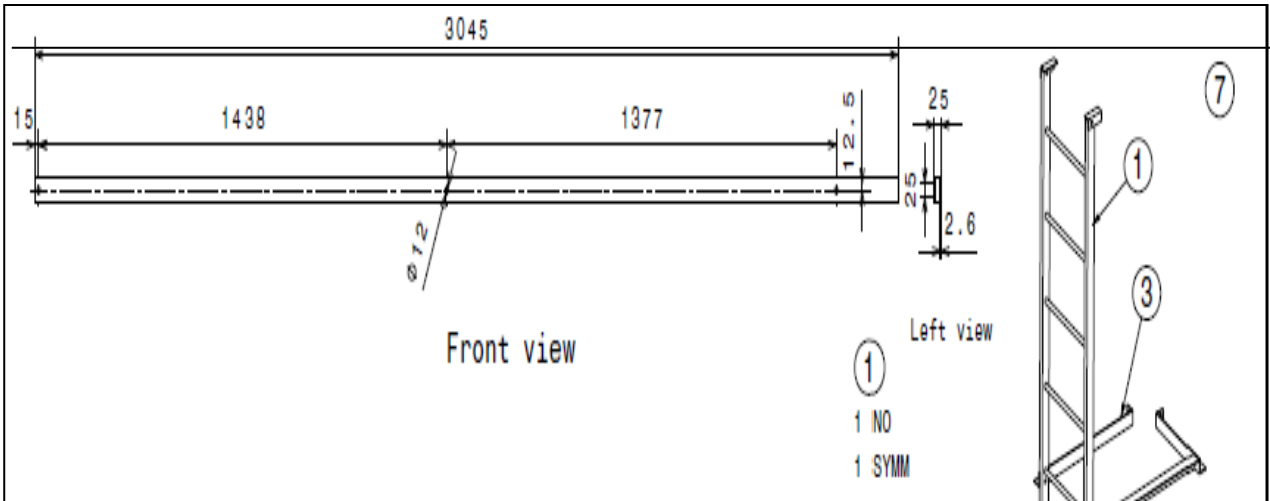

| | | |
|---|---|------------------------------|
| CHATTISGARH STATE RENEWABLE ENERGY DEVELOPMENT AGENCY (CREDA) | | |
| PROJECT TITLE 6 MTR 5000 LTR SOLAR WATER TANK STRUCTURE 900 WATTS | | |
| SCALE: - NTS | TITLE 6 MTR 5000 LTR SOLAR WATER TANK STRUCTURE 900 WATTS | REF No. AK |
| projection | Org No. CREDA 002 | SHEET No. 8 OF 9 REV - 01 |

④ 1 NO
1 SYMM

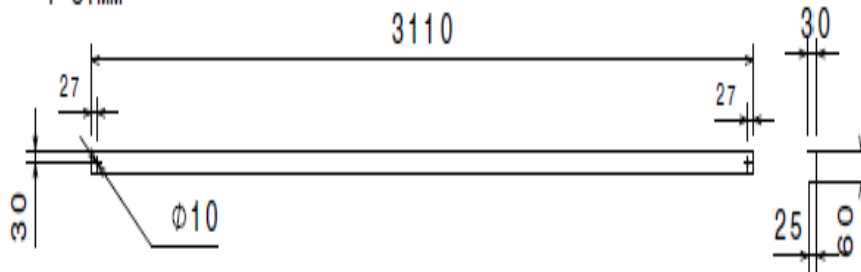

⑤ 1 NO
1 SYMM

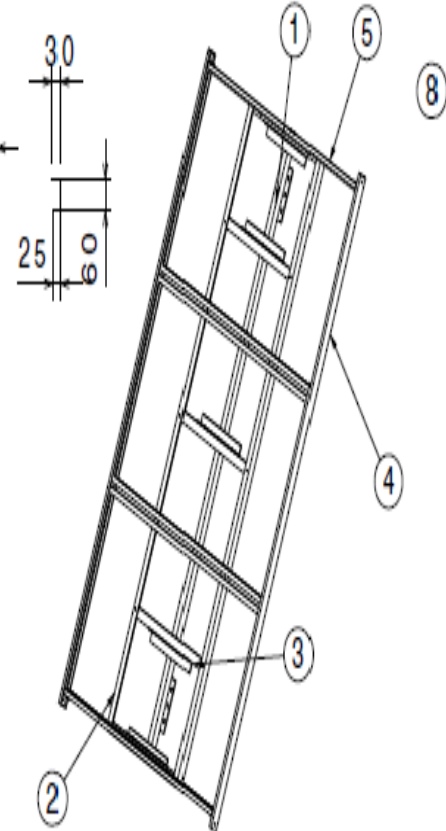
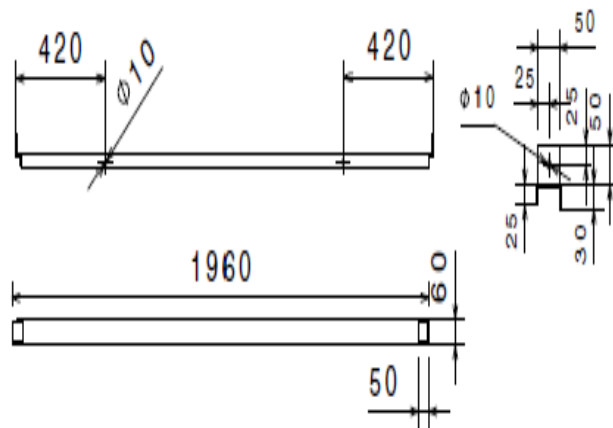

Isometric view

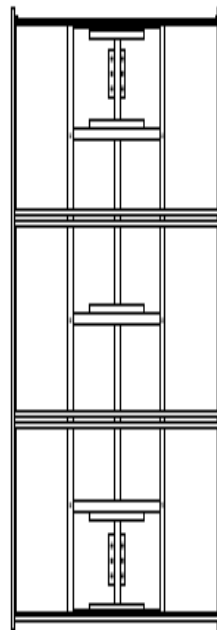

Front view

CHATTISGARH STATE RENEWABLE ENERGY
DEVELOPMENT AGENCY (CREDA)

PROJECT TITLE 6 MTR 5000 LTR SOLAR WATER TANK
STRUCTURE 900 WATTS

SCALE: - NTS TITLE 6 MTR 5000 LTR SOLAR WATER
TANK STRUCTURE 900 WATTS

REF No. AK

projection

Dwg No.

SHEET No. 7 OF 9



CREDA 002

REV - 01

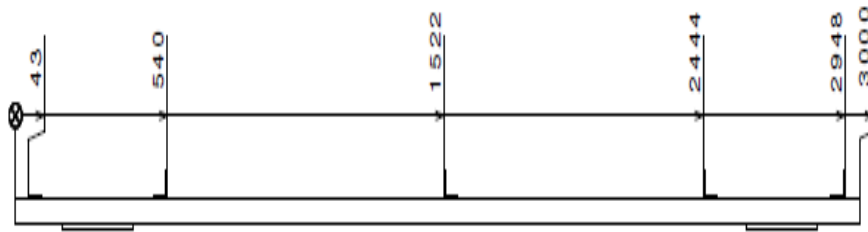

Front view

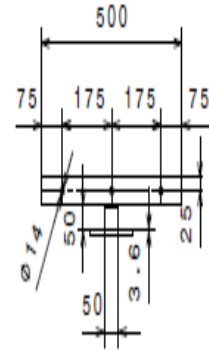

Side view

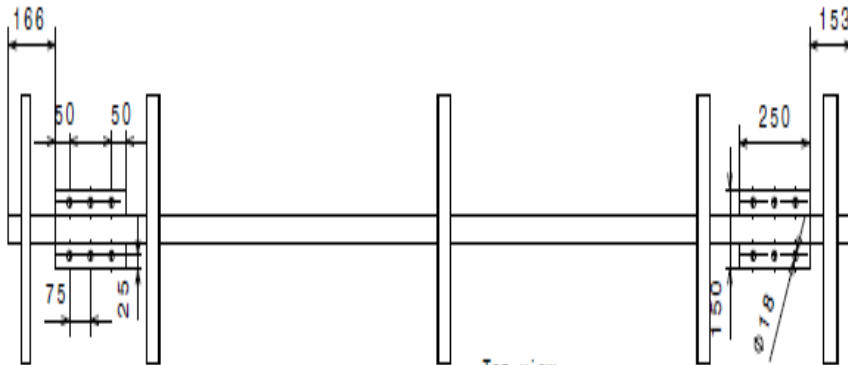

Top view

①

1 NO

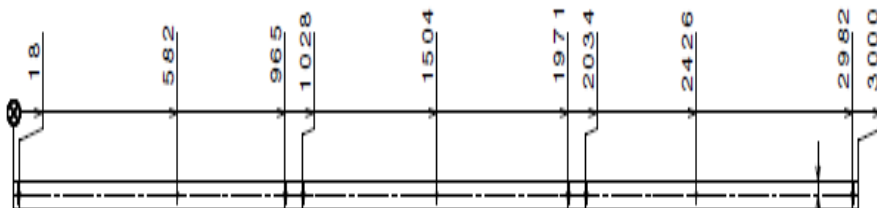

Front view



Left view

②

1 NO

1 SYMM

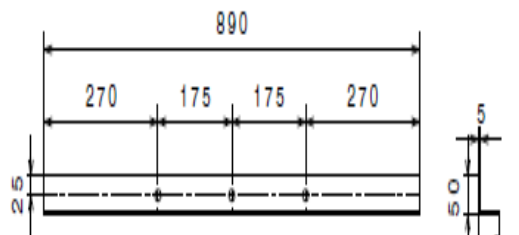

Front view

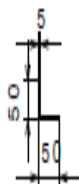

Left view

③

5 NO'S

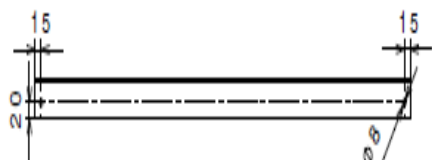

Top view

| | | |
|---|---|------------------|
| CHATTISGARH STATE RENEWABLE ENERGY DEVELOPMENT AGENCY (CREDA) | | |
| PROJECT TITLE 6 MTR 5000 LTR SOLAR WATER TANK STRUCTURE 900 WATTS | | |
| SCALE:-NTS | TITLE 6 MTR 5000 LTR SOLAR WATER TANK STRUCTURE 900 WATTS | REF No. AK |
| projection | Drwg No. CREDA 002 | SHEET No. 8 OF 9 |
| | | REV - 01 |

2 NOS

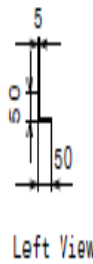
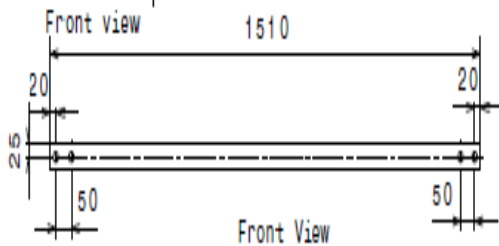
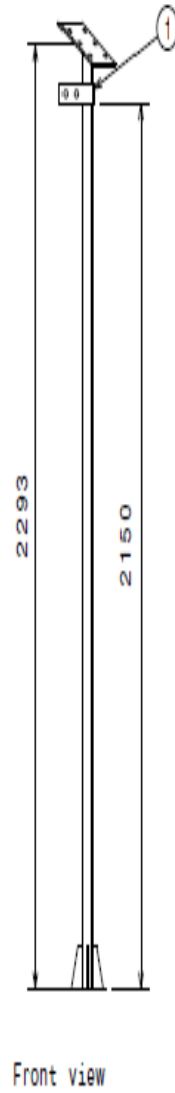
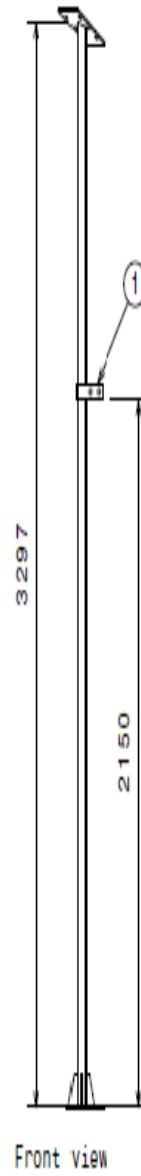
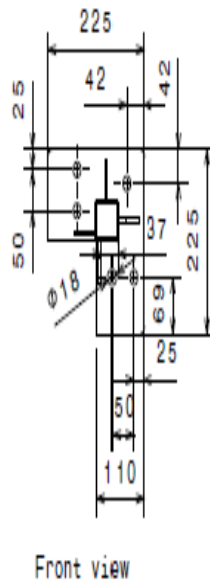
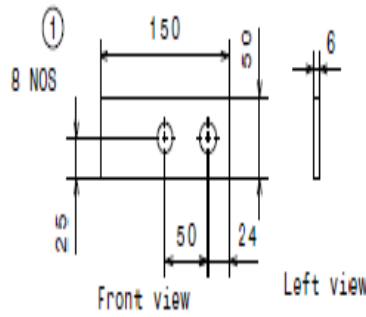
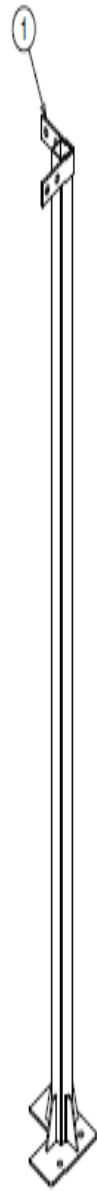
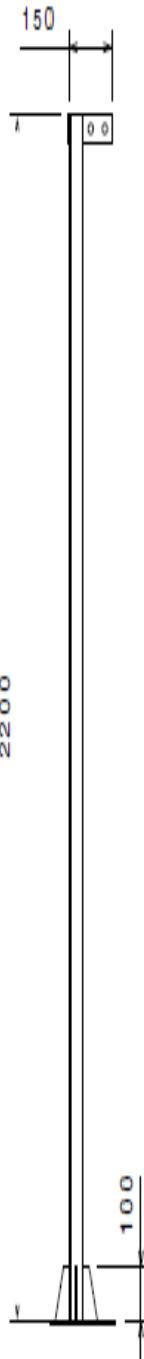

| | | |
|--|---|------------------------------|
| CHATTISGARH STATE RENEWABLE ENERGY DEVELOPMENT AGENCY (CREDA) | | |
| PROJECT TITLE 6 MTR 5000 LTR SOLAR WATER TANK STRUCTURE 900 WATTS | | |
| SCALE: -VTS | TITLE 6 MTR 5000 LTR SOLAR WATER TANK STRUCTURE 900 WATTS | REF No. AK |
| projection | Dwg No. CREDA 002 | SHEET No. 0 OF 0 REV - 01 |

02. Complete drawing of 900W/ 1 HP, 6Mtr Staging, 10KL Solar Dual Pump structure & Civil Works

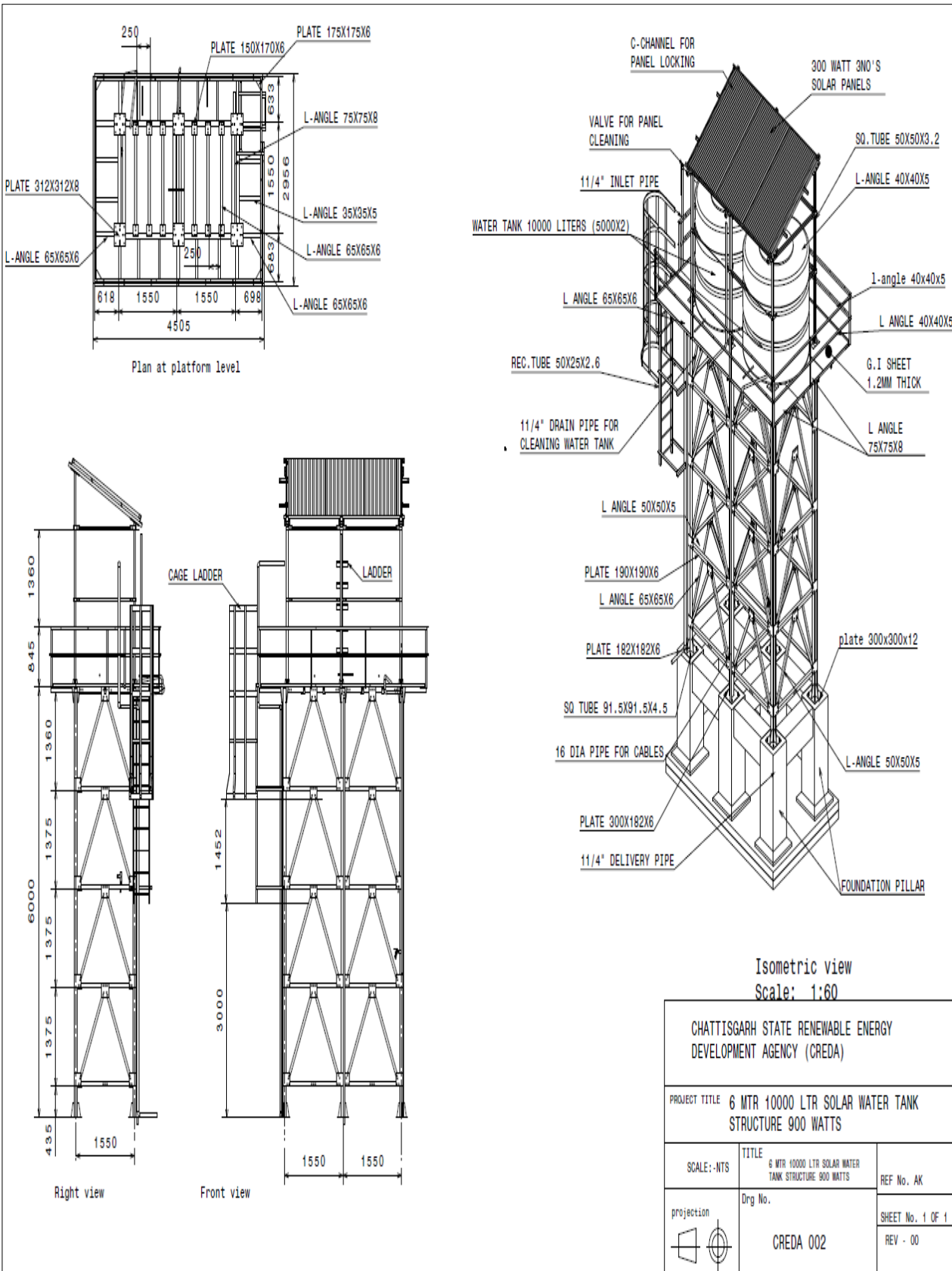

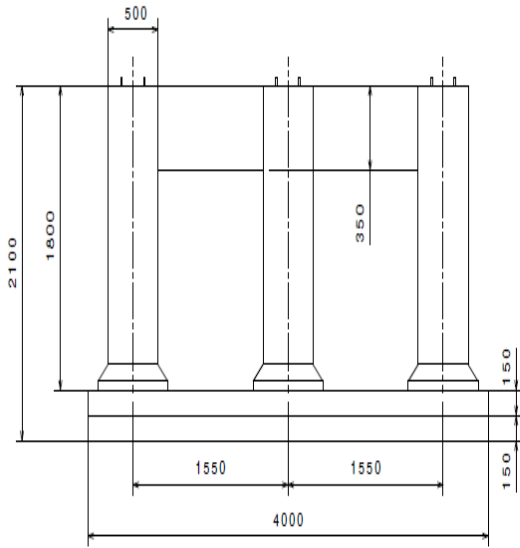

Front view

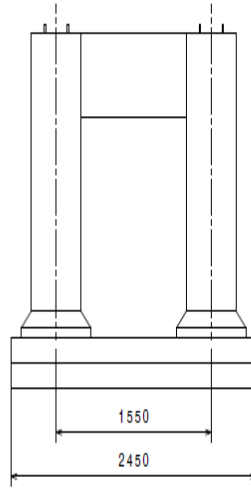

Left view

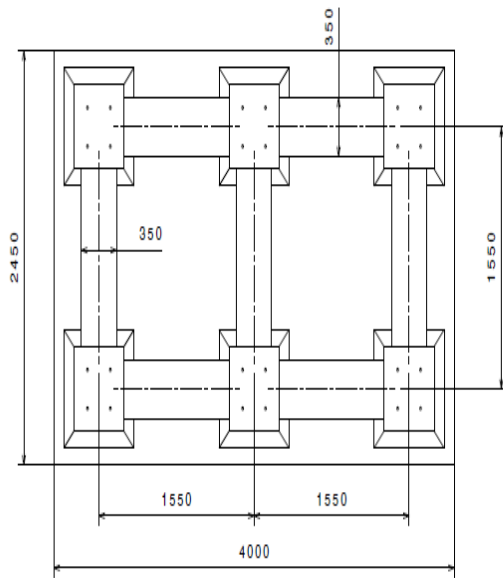

Top view

Cement Concrete Mix – M20

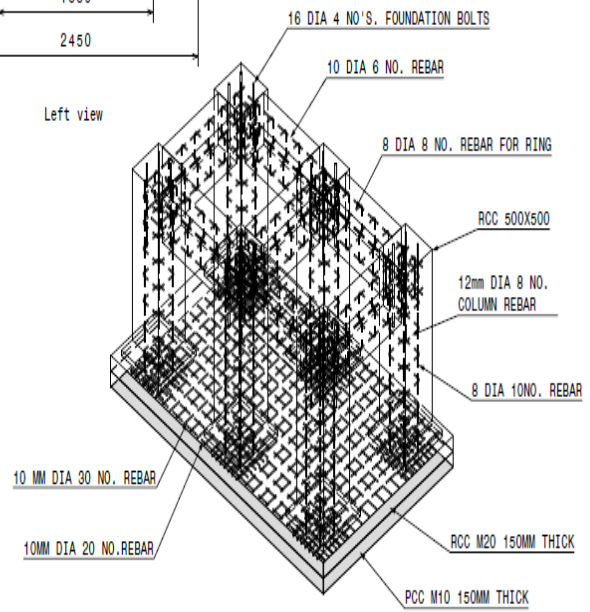

Isometric view

CHATTISGARH STATE RENEWABLE ENERGY
DEVELOPMENT AGENCY (CREDA)

PROJECT TITLE 6 MTR 10000 LTR SOLAR WATER
TANK STRUCTURE 900 WATTS

SCALE:-NTS

TITLE
6 MTR 10000 LTR SOLAR WATER
TANK STRUCTURE 900 WATTS

REF No. AK

projection



Drg No.

CREDA- 001

SHEET No. 1 OF 2

REV - 00

Structure Part Drawings (900WATT,6Mtr,1HP,10KL)

| | | | | |
|--|---|-------------------|--|--------------------------|
| <p>Front view</p> | <p>Left view</p> <p>QTY: 18 NO'S</p> <p style="text-align: center;">(31)</p> | | | |
| <p>Front view</p> | <p>Left view</p> <p>QTY: 10 NO'S</p> <p style="text-align: center;">(32)</p> | | | |
| <p>Front view</p> | <p>Left view</p> <p>QTY: 24 NO'S SYMM 24 NO'S</p> <p style="text-align: center;">(33)</p> | | | |
| <p>QTY: 32 NO'S</p> <p>Front view</p> <p>Left view</p> <p style="text-align: center;">(34)</p> | <p>QTY: 8 NO'S</p> <p>Front view</p> <p>Left view</p> <p style="text-align: center;">(35)</p> | | | |
| <p>ALL DIMENSIONS ARE IN MM</p> | | | | |
| <p>This drawing is our property. it can't be reproduced or communicated without our written agreement.</p> | | | | |
| <h2 style="margin: 0;">CREDA</h2> | | | | |
| <p>PROJECT: 6MTR 6 POLE 1550 PCD SOLAR STRUCTURE</p> | | | | |
| <p>drawn by: REDDY</p> | <p>03-06-2019</p> | <p>SCALE: NTS</p> | <p>TITLE: SOLAR WATER TANK STRUCTURE</p> | <p>REF No.</p> |
| <p>checked by:</p> | <p>DESIGNED BY:</p> | <p>projection</p> | <p>Org No. M&C-SWS-001</p> | <p>SHEET No.10 OF 14</p> |
| | | | | <p>REV - 00</p> |

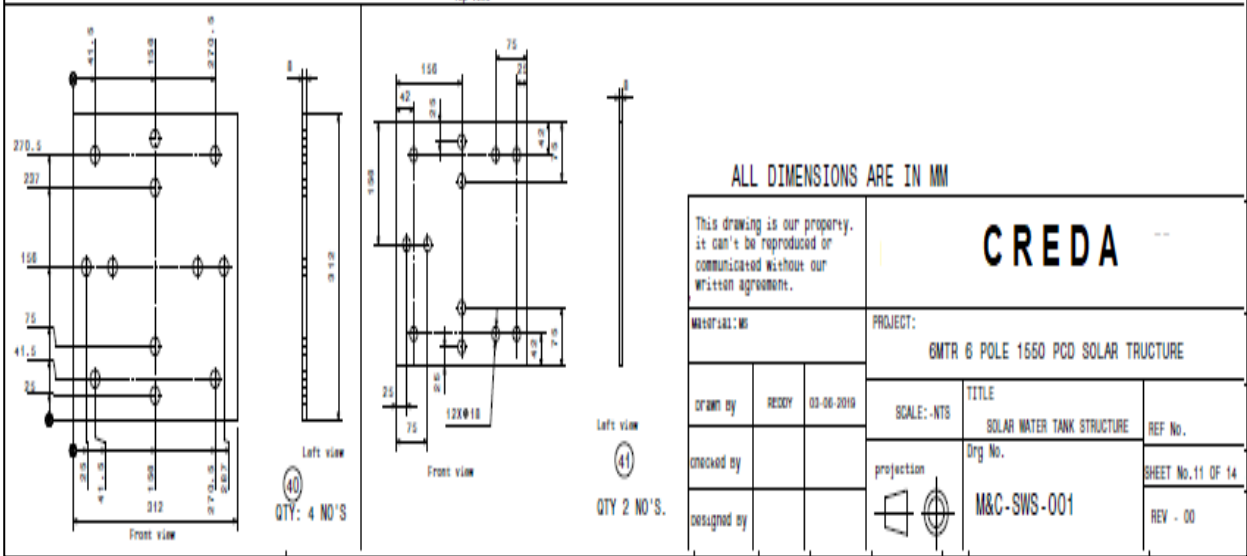
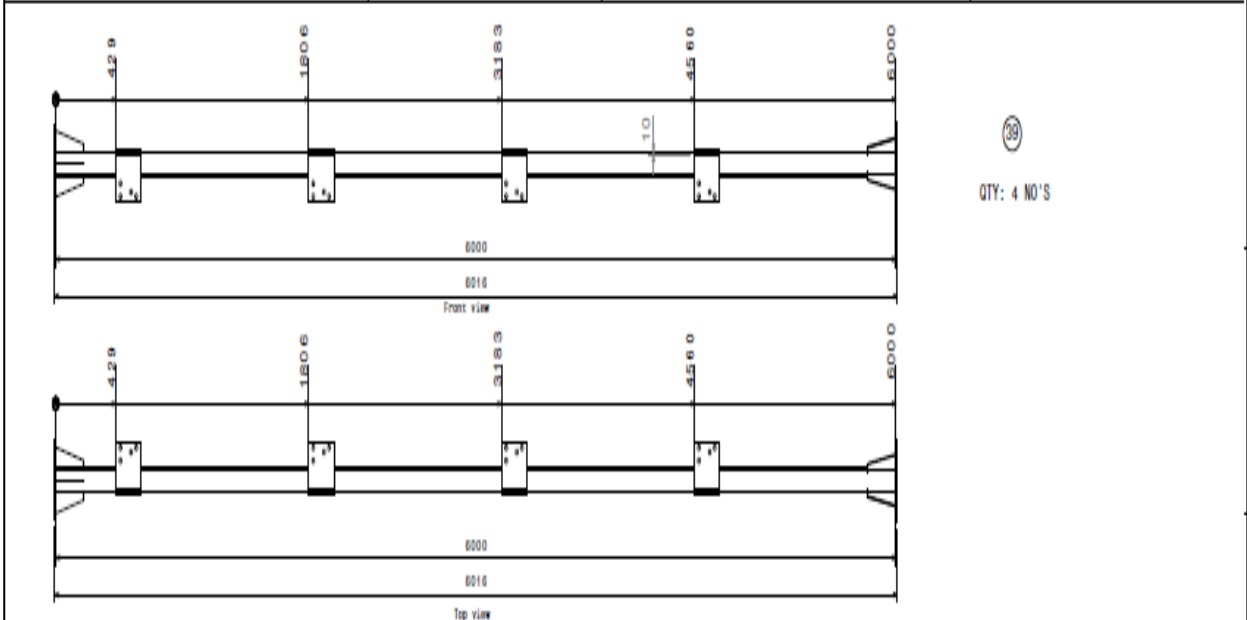
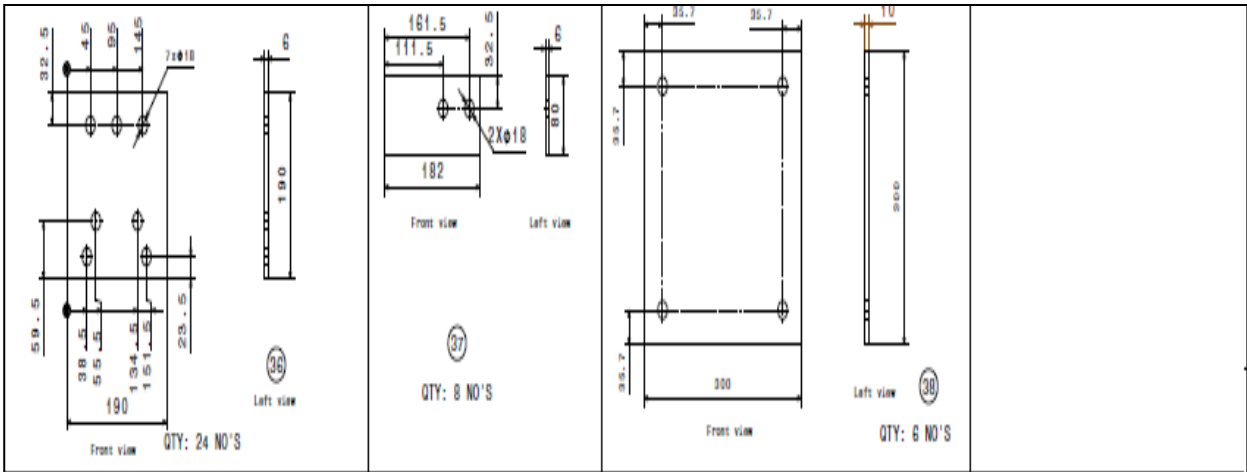

ALL DIMENSIONS ARE IN MM

| | | | |
|---|------------------|--|-------------------------------------|
| This drawing is our property. it can't be reproduced or communicated without our written agreement. | | CREDA | |
| Material: M | | PROJECT: GMTR 6 POLE 1550 PCD SOLAR STRUCTURE | |
| drawn by | REDDY 03-06-2019 | SCALE: NTS | TITLE SOLAR WATER TANK STRUCTURE |
| checked by | | projection | REF No. |
| designed by | | | Org No. M&C-SWS-001 |
| | | | SHEET No.11 OF 14 |
| | | | REV - 00 |

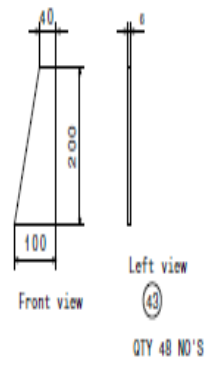
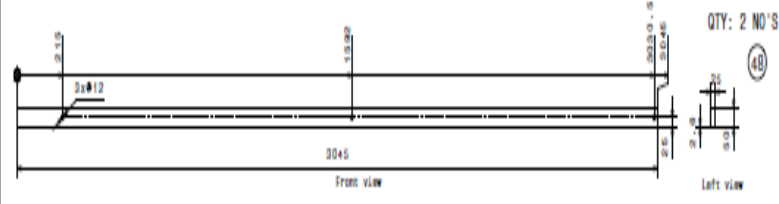
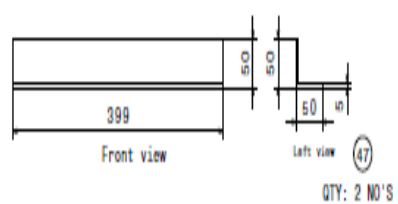
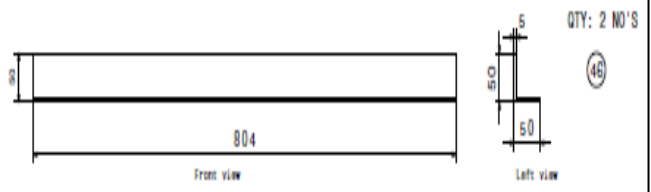
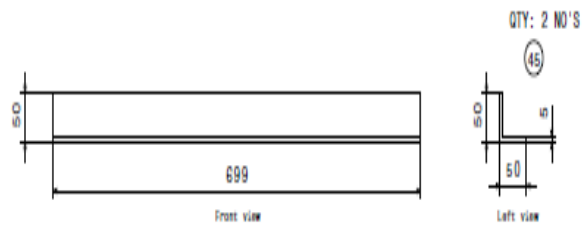
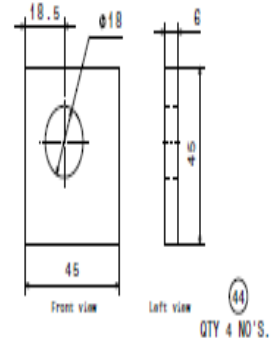
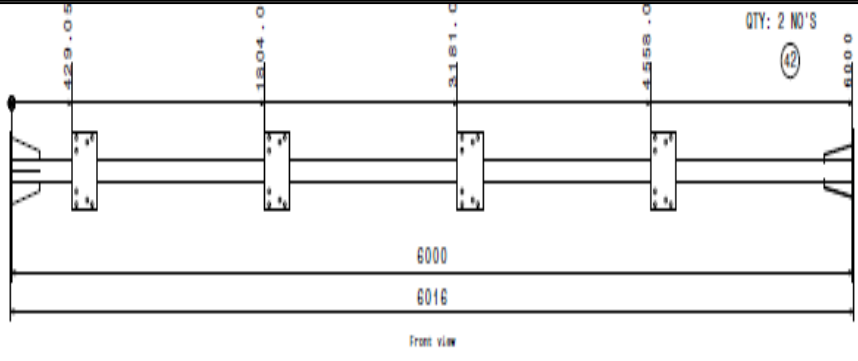

ALL DIMENSIONS ARE IN MM

This drawing is our property. it can't be reproduced or communicated without our written agreement.

CREDA

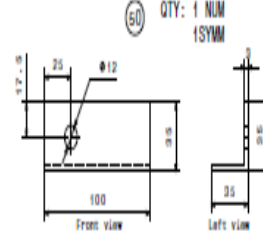
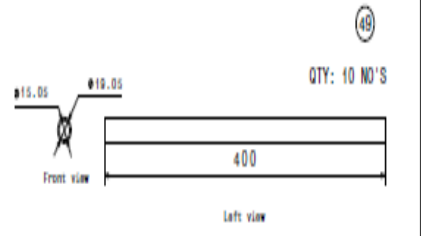

| | | |
|--------------|-------|------------|
| Material: M8 | | |
| Drawn by | REDDY | 03-06-2019 |
| Checked by | | |
| Designed by | | |

| | | |
|---|----------------------------|--------------------|
| PROJECT: GMTR 6 POLE 1550 PCD SOLAR STRUCTURE | | |
| SCALE: NTS | TITLE | REF No. |
| projection | SOLAR WATER TANK STRUCTURE | |
| | Dwg No. | SHEET No. 12 OF 14 |
| | M&C-SWS-001 | REV - 00 |

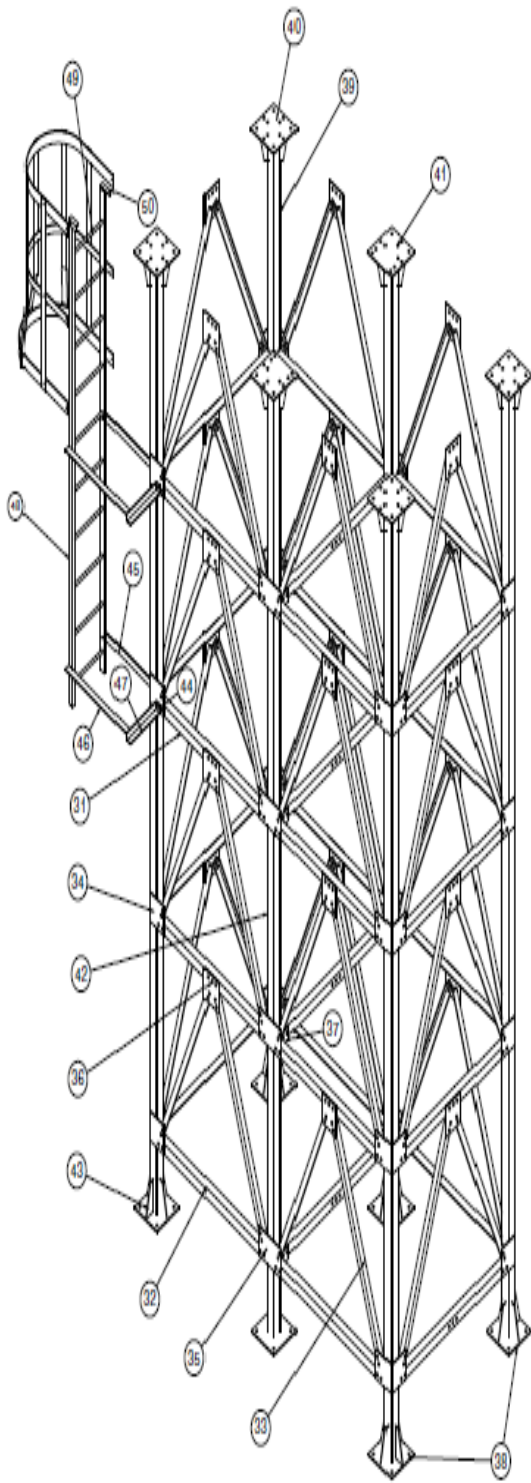

Isometric view

ALL DIMENSIONS ARE IN MM

| | | | | |
|---|-------|------------|---|-------------------------------------|
| This drawing is our property. it can't be reproduced or communicated without our written agreement. | | | CREDA | |
| Material: W | | | PROJECT: GMTR 6 POLE 1650 PCD SOLAR STRUCTURE | |
| drawn by | REDDY | 03-06-2019 | SCALE: - NTS | TITLE SOLAR WATER TANK STRUCTURE |
| checked by | | | projection | REF No. |
| designed by | | | | Drg No. M&C-SWS-001 |

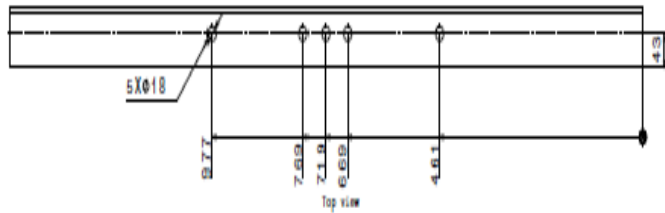
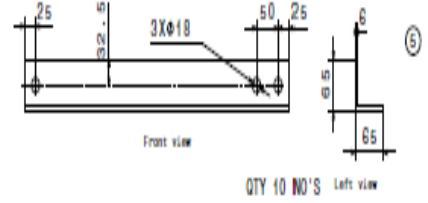
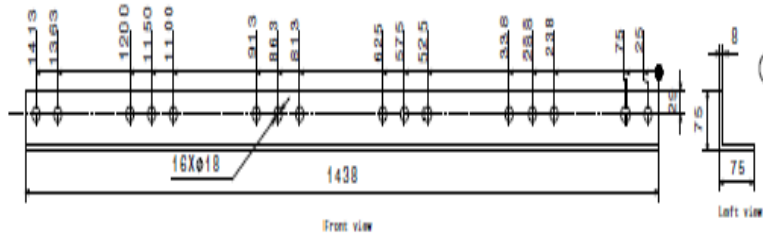

QTY 4 NO'S.

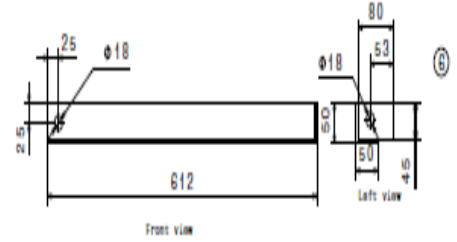

QTY 6 NO'S
6 SYM

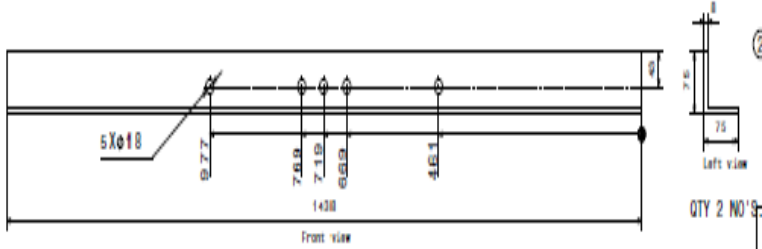

QTY 2 NO'S.

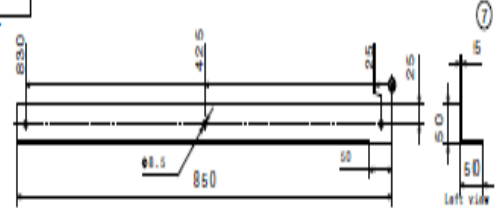

QTY 6 NO'S

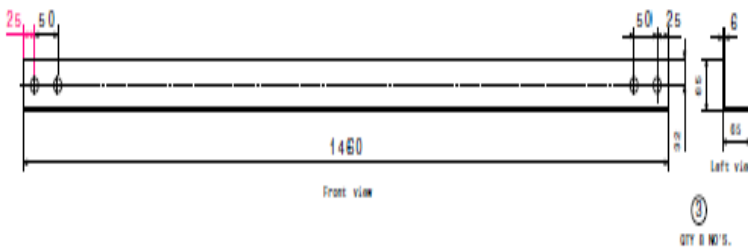
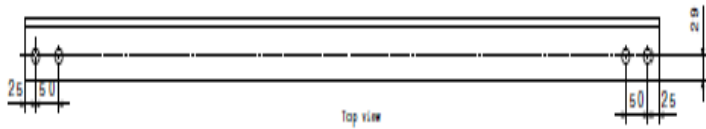

QTY 8 NO'S.

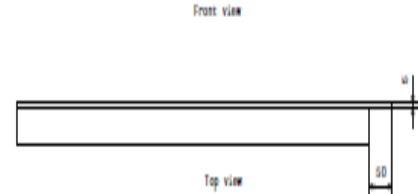

ALL DIMENSIONS ARE IN MM

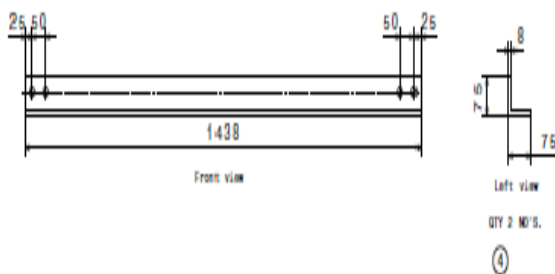

QTY 2 NO'S.

④

This drawing is our property.
it can't be reproduced or
communicated without our
written agreement.

CREDA

DATE: 03-06-2019

PROJECT:

BMTR 6 POLE 1550 PCD SOLAR STRUCTURE

drawn by: REDDY

SCALE: -NTS

TITLE

SOLAR WATER TANK STRUCTURE

REF No.

checked by:

projection

Org No.

M&C-SWS-001

SHEET No. 1 OF 1

designed by:



REV - 00

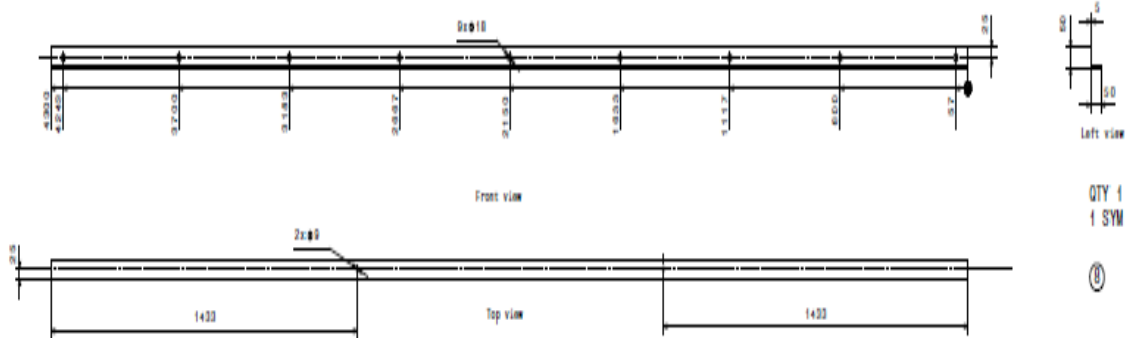

QTY 1 NO.
1 SYM
⑨

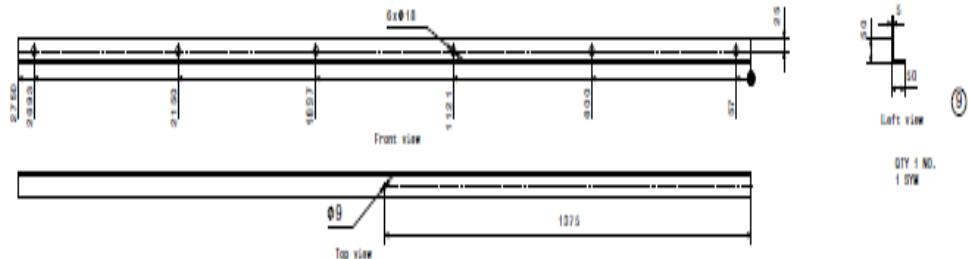

QTY 1 NO.
1 SYM
⑩

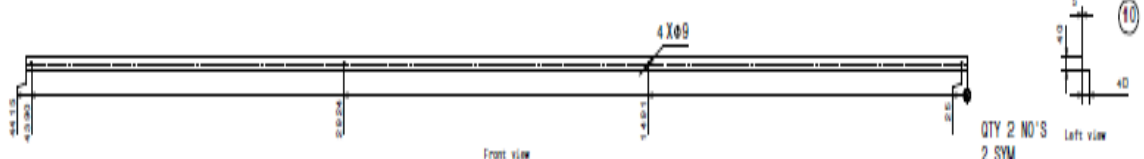

QTY 2 NO'S
2 SYM
⑪

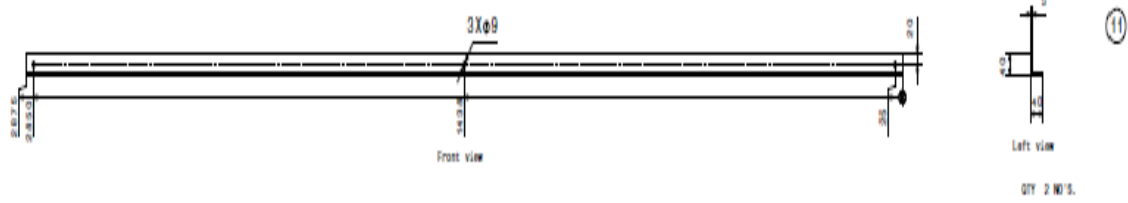

QTY 2 NO'S.
⑫

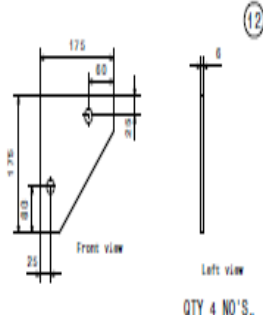

QTY 4 NO'S.
⑬

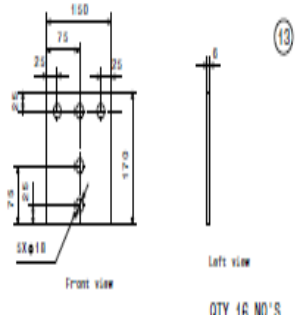

QTY 16 NO'S.
⑭

ALL DIMENSIONS ARE IN MM

| | | | | |
|---|-------|------------|---|-------------------------------------|
| This drawing is our property. it can't be reproduced or communicated without our written agreement. | | | CREDA | |
| MATERIAL: MS | | | PROJECT: 6MTR 6 POLE 1650 PCD SOLAR STRUCTURE | |
| drawn by | REDDY | 03-06-2019 | SCALE:- NTS | TITLE SOLAR WATER TANK STRUCTURE |
| checked by | | | projection | REF No. |
| designed by | | | | Drwg No. M&C-SWS-001 |
| | | | | SHEET No. 2 OF 14 REV - 00 |

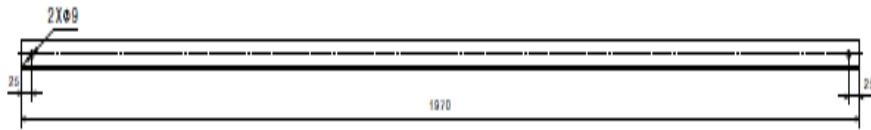

Front view

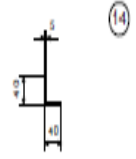

Left view

QTY 2 NO'S.



Front view



Left view

QTY 3 NO'S.

ALL DIMENSIONS ARE IN MM

| | | | | | |
|--|------------|--|--|-------------------------------------|-------------------|
| This drawing is our property. it can't be reproduced or communicated without our written agreement. | | | CREDA | | |
| MATERIAL: MS | | | PROJECT: 6MTR 6 POLE 1650 PCD SOLAR STRUCTURE | | |
| drawn by reddy | 03-06-2018 | | SCALE:- NTS | TITLE SOLAR WATER TANK STRUCTURE | REF No. |
| checked by | | | projection | Dwg No. M&C-SWS-001 | SHEET No. 3 OF 14 |
| designed by | | | | | REV - 00 |

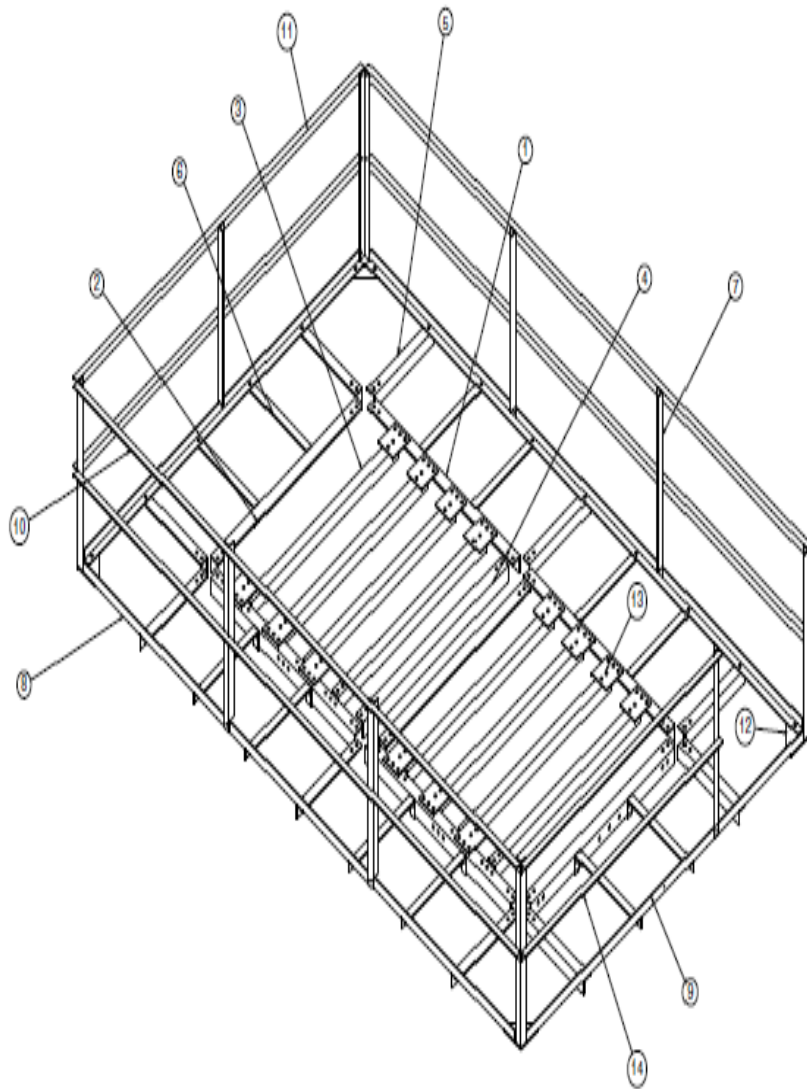

Isometric view
Scale: 1:15

ALL DIMENSIONS ARE IN MM

| | | | | |
|---|-------|------------|---|-------------------------------------|
| This drawing is our property. it can't be reproduced or communicated without our written agreement. | | | CREDA | |
| MATERIAL: MS | | | PROJECT: 6MTR 6 POLE 1550 PCD SOLAR STRUCTURE | |
| drawn by | REDDY | 03-06-2019 | SCALE:- NTS | TITLE SOLAR WATER TANK STRUCTURE |
| checked by | | | projection  | REF No. |
| designed by | | | | Org No. M&C-SWS-001 |

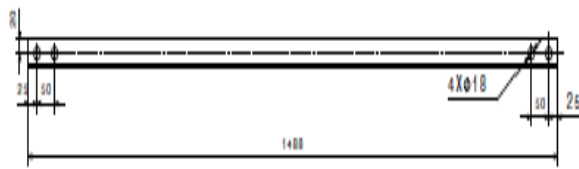

Front view(2)

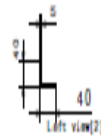

25

QTY 4 NO'S



Front view



Left view

QTY 1 NO.
1 SYM

26

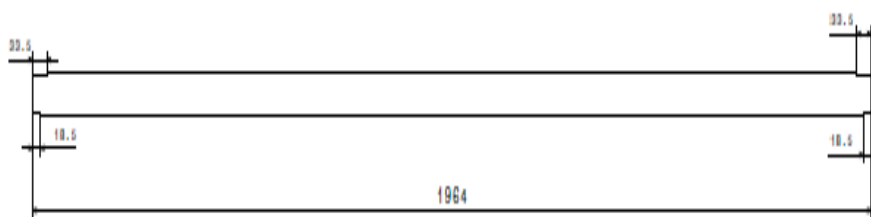

Front view



Left view

QTY 1 NO.
1 SYM

27



Top view

ALL DIMENSIONS ARE IN MM

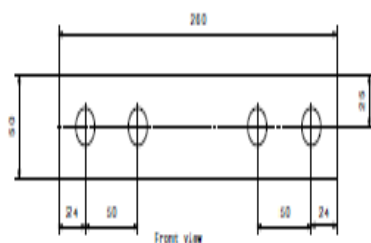

Front view



Left view

QTY 2 NO'S.

28

This drawing is our property.
it can't be reproduced or
communicated without our
written agreement.

CREDA

MATERIAL: MS

PROJECT:

6MTR 6 POLE 1650 PCD SOLAR STRUCTURE

drawn by REJOY 03-06-210

SCALE: -NTS

TITLE

SOLAR WATER TANK STRUCTURE

REF No.

checked by

projection

Drq No.

M&C-SWS-001

SHEET No. 7 OF 14

designed by



REV - 00

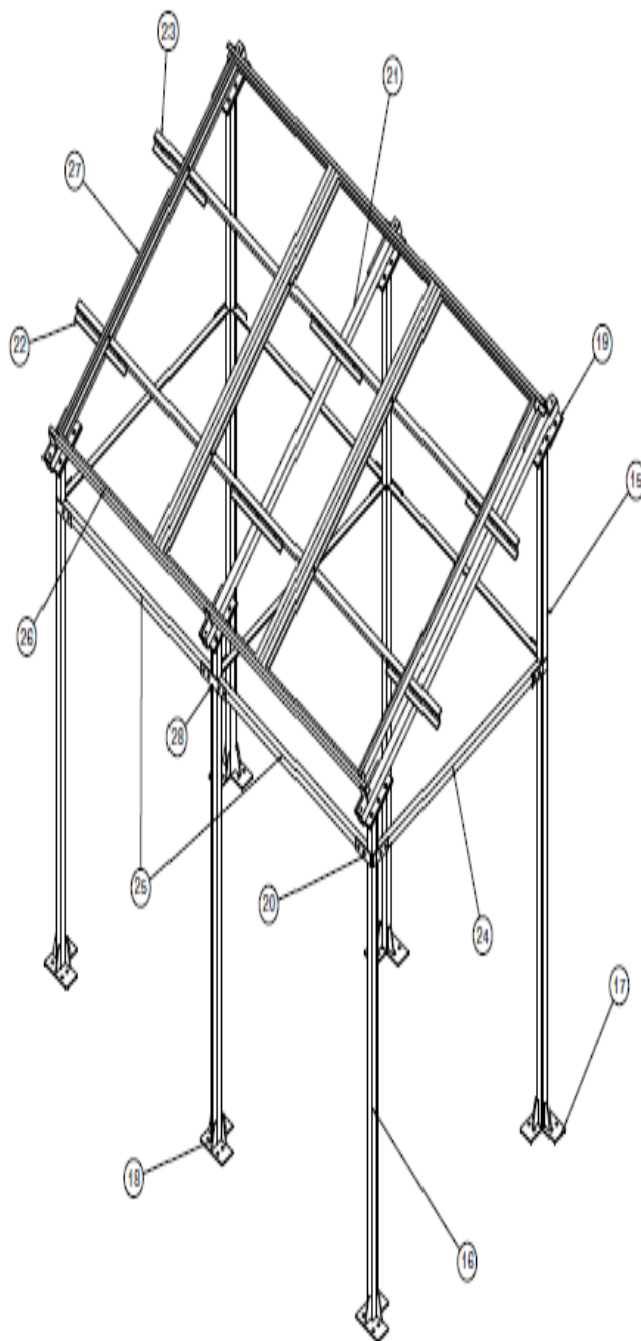

Isometric view

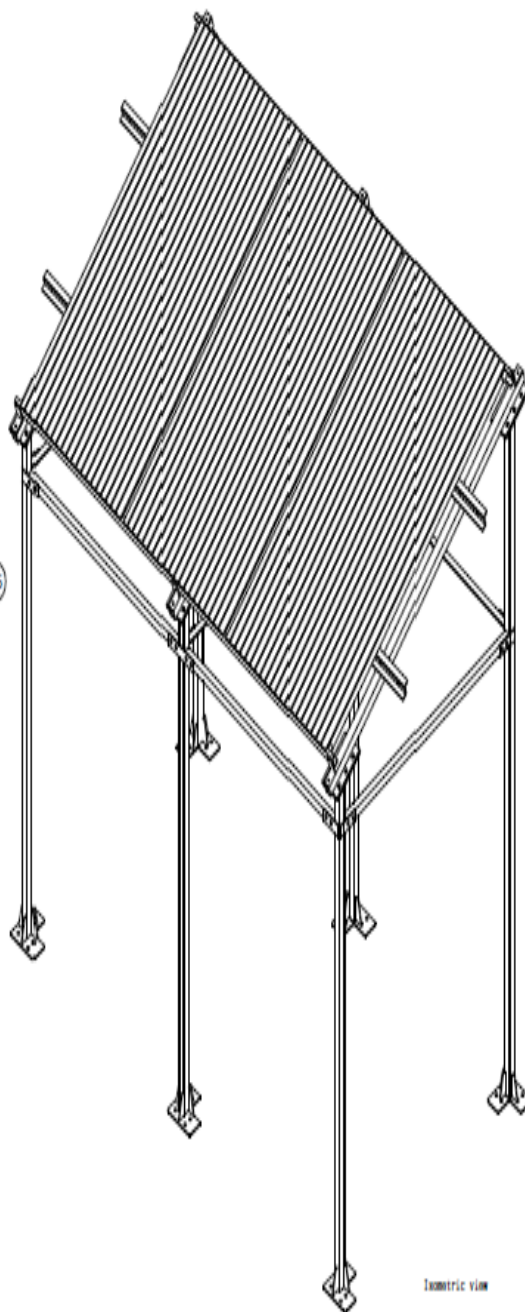

Isometric view

ALL DIMENSIONS ARE IN MM

This drawing is our property.
it can't be reproduced or
communicated without our
written agreement.

CREDA

MATERIAL: MS

PROJECT:

BMTR 6 POLE 1550 PCD SOLAR STRUCTURE

drawn by REJOY 03-06-2010

SCALE: -NTS

TITLE
SOLAR WATER TANK STRUCTURE

REF No.

checked by

projection

Org No.

SHEET No. 8 OF 14

designed by



M&C-SWS-001

REV - 00

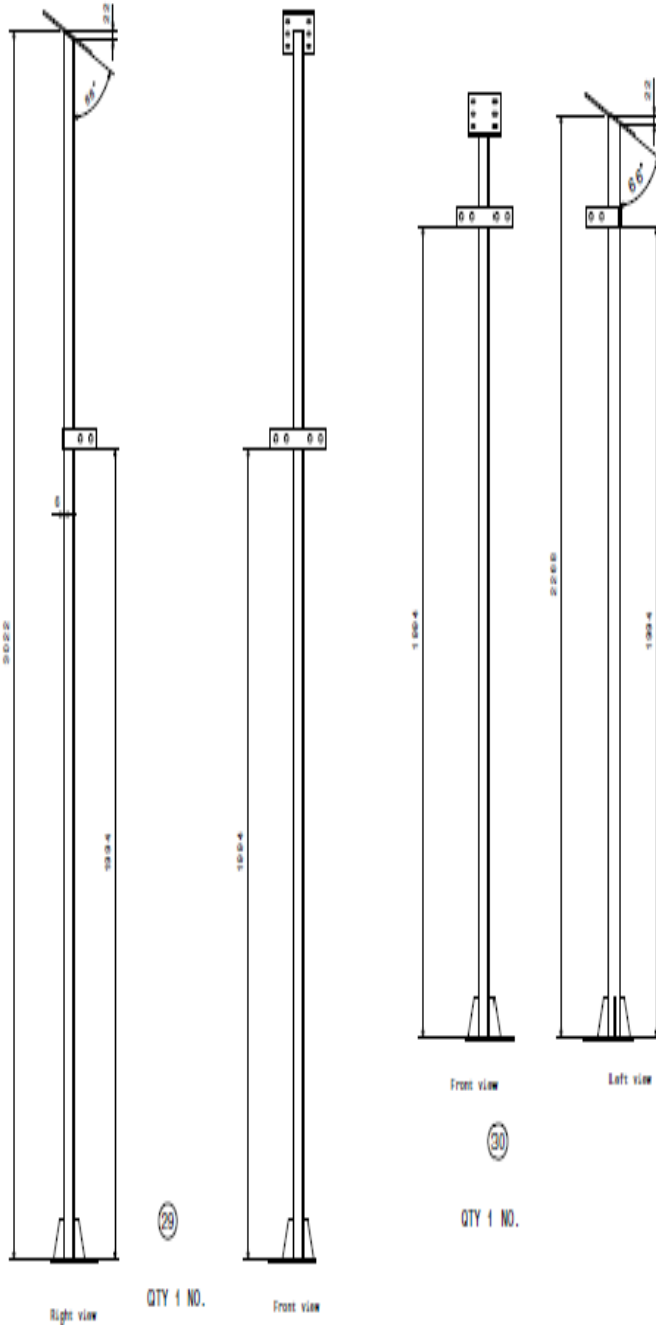
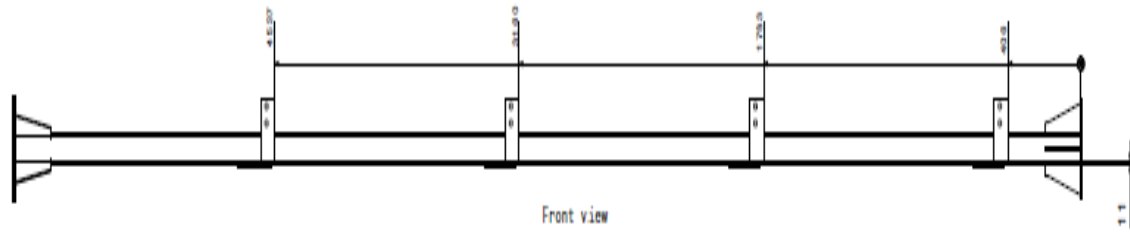

ALL DIMENSIONS ARE IN MM

This drawing is our property.
it can't be reproduced or
communicated without our
written agreement.

CREDA

Material: MS

PROJECT:

BMTR 6 POLE 1550 PCD SOLAR STRUCTURE

drawn by REEDY 03-06-2019

SCALE: -NTS

TITLE

SOLAR WATER TANK STRUCTURE

REF No.

checked by

projection

Org No.

M&C-SWS-001

SHEET No. 0 OF 14

designed by



REV - 00

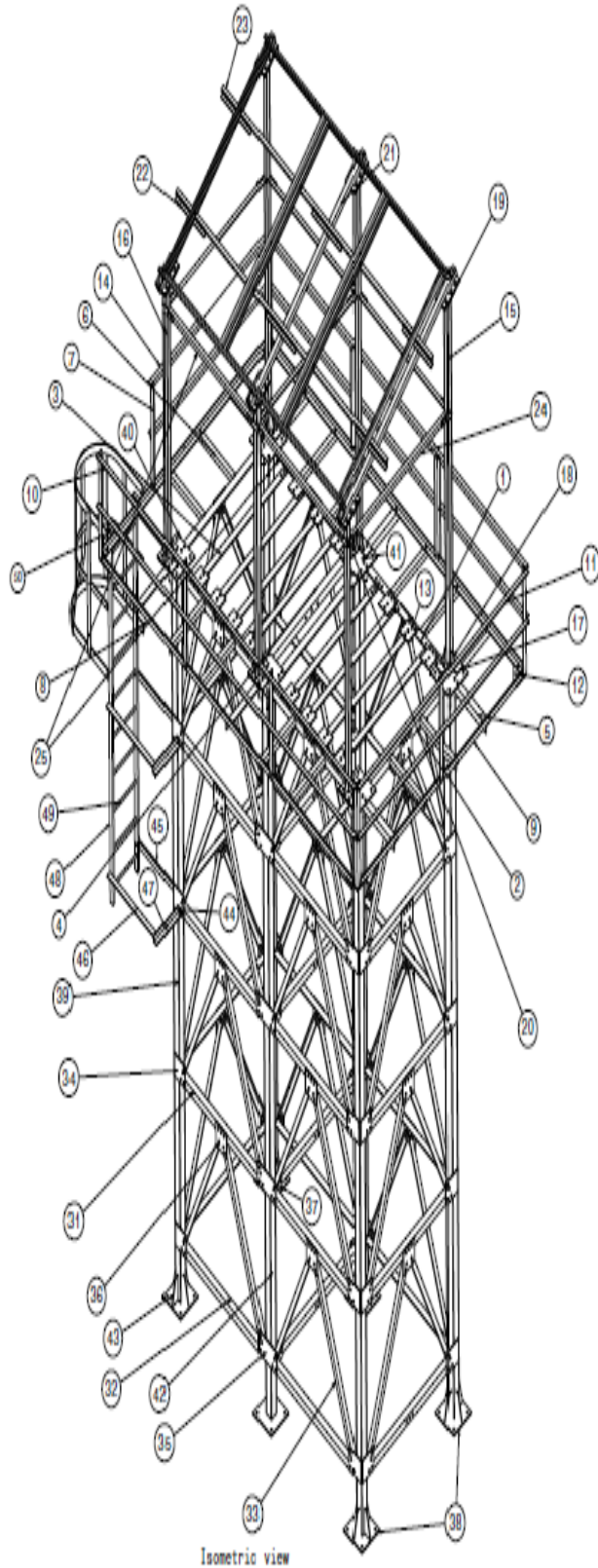

ALL DIMENSIONS ARE IN MM

| | | | | |
|---|-------|------------|---|-------------------------------------|
| This drawing is our property. it can't be reproduced or communicated without our written agreement. | | | CREDA | |
| MATERIAL: MS | | | PROJECT: 6MTR 6 POLE 1550 PCD SOLAR STRUCTURE | |
| drawn by | REDOY | 03-08-2016 | SCALE: NTS | TITLE SOLAR WATER TANK STRUCTURE |
| checked by | | | projection | REF No. |
| designed by | | |  | Org No. M&C-SWS-001 |
| | | | | SHEET No. 14 OF 14 |
| | | | | REV - 00 |